

# SRM Series Multi-Cavity Vessels



SRM Multi-cavity filter vessels offer large surface areas capable of handling up to 5600 gpm in a single housing. Increasing surface area allows for longer processing time prior to filter change-out. Containing anywhere from 2 to 28 bags/baskets in a single vessel, our standard side-inlet side-outlet design offers the greatest inlet/outlet flexibility and doesn't require a platform to be built in order to change-out or clean the filter elements or strainers (*refer to diagram and charts*).

## Standard Features

- Inlet/outlet orientation: Ergonomically superior Side-in Side-out (standard) or Bottom-in Bottom-out (optional)
- Low pressure drop, positive cover seal
- Easily cleaned
- Stainless Steel perforated baskets (standard)
- ASME code stamp available
- Swing bolt closures
- 1" to 2" NPT drain port on bottom
- .50" to 1" NPT pressure gauge/vent tap
- Pipe sizes from 2" to 14" RFF connections
- Davit Lift
- Compression Device

## Optional Features

- Epoxy coating, electro-polish, and fuse or Teflon® coating
- Higher pressure ratings available up to 3,000 psi
- Variety of lid-lifting devices — Hydraulic, Jack, or Manual Wheel Davit
- Jacketing
- Sanitary construction
- Wire mesh support baskets
- Mesh-lined basket for straining applications — 50 micron and higher
- Differential pressure gauge taps

### Dimensions Chart for Multi-Bag Vessels, Bottom-in Bottom-out

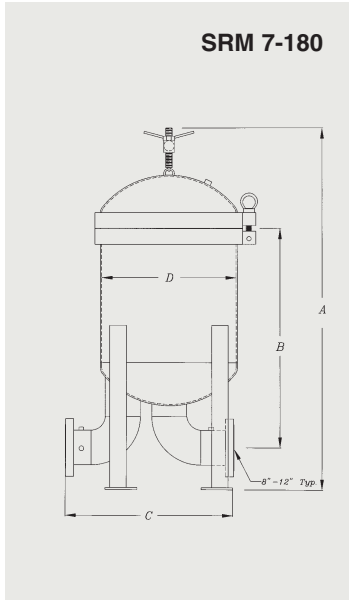

Unit Type	No. of Baskets or Bags	Std. Conn. RFF	A	B	C	D	Surface Area Sq. Ft.	Max. GPM Strainer	Max. GPM Filter Bags	Shipping Weight lbs.
SRM 2	2	3"	58"	44"	26"	16"	9.0	600	400	275
SRM 3	3	3"	67"	44"	26"	18"	13.5	900	600	625
SRM	4	4"	79"	46"	28"	24"	18.0	1200	800	875
SRM 5	5	6"	82"	48"	32"	26"	22.5	1500	1000	1108
SRM 6	6	6"	82"	48"	32"	26"	27.0	1800	1200	1130
SRM 7	7	8"	85"	59"	36"	30"	31.5	2100	1400	1170
SRM 8	8	8"	89"	59"	36"	30"	35.5	2400	1600	1355
SRM 10	10	10"	90"	64"	46"	36"	44.5	300	2000	1500
SRM 12	12	12"	90"	64"	46"	42"	54.0	3600	2400	1610

### Dimensions Chart for Ergonomically Superior Multi-Bag Vessels, Side-in Side-out

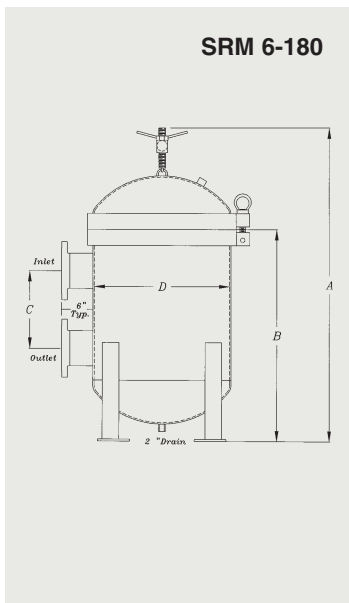

Unit Type	No. of Baskets or Bags	Std. Conn. RFF	A	B	C	D	Surface Area Sq. Ft.	Max. GPM Strainer	Max. GPM Filter Bags	Shipping Weight lbs.
SRM 2	2	3	55"	40"	12 <sup>3</sup> / <sub>4</sub> "	16"	9.0	600	400	250
SRM 3	3	3	55"	40"	12 <sup>3</sup> / <sub>4</sub> "	18"	13.5	900	600	565
SRM 4	4	4	55"	42"	12 <sup>3</sup> / <sub>4</sub> "	24"	18.0	1200	800	785
SRM 5	5	6	60"	42"	12 <sup>3</sup> / <sub>4</sub> "	26"	22.5	1500	1000	995
SRM 6	6	6	60"	42"	12 <sup>3</sup> / <sub>4</sub> "	26"	27.0	1800	1200	1020
SRM 7	7	8	66"	47"	15"	30"	31.5	2100	1400	1055
SRM 8	8	8	66"	47"	15"	30"	35.5	2400	1600	1220
SRM 9	9	10	74"	52"	18"	36"	40.0	2700	1800	1310
SRM 10	10	10	74"	52"	18"	36"	44.5	3000	2000	1350
SRM 11	11	12	85"	62"	22"	36"	49.5	3300	2200	1420
SRM 12	12	12	85"	62"	22"	36"	54.0	3600	2400	1450

All the above dimensions are for **REFERENCE ONLY**.