

SRMB

Multi-Basket Vessels

The SRMB Multi-Basket Filter Vessel offers large surface areas capable of handling up to 5600 gpm in a single housing. Increasing surface area allows for longer processing time prior to filter change-out.

Containing anywhere from 2 to 28 bags/baskets in a single vessel, our standard side-inlet/side-outlet design offers the greatest inlet/outlet flexibility and doesn't require a platform to be built, in order to change-out or clean the filter elements or strainers.



SRMB Side In/Side Out

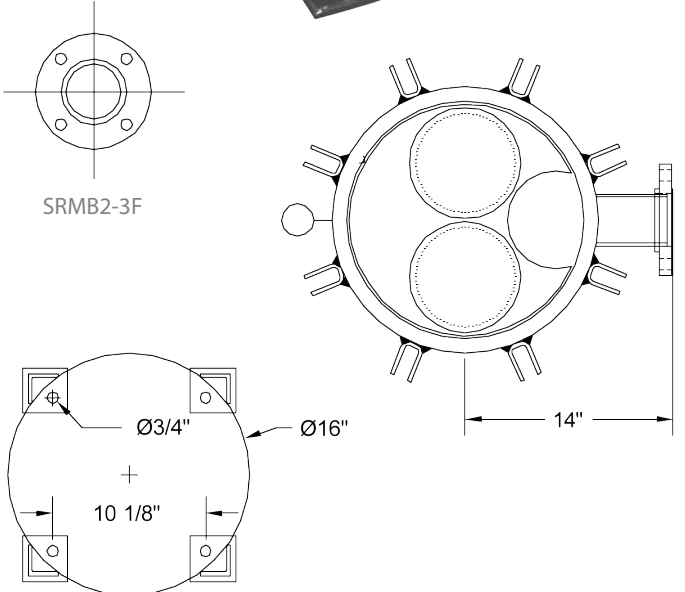
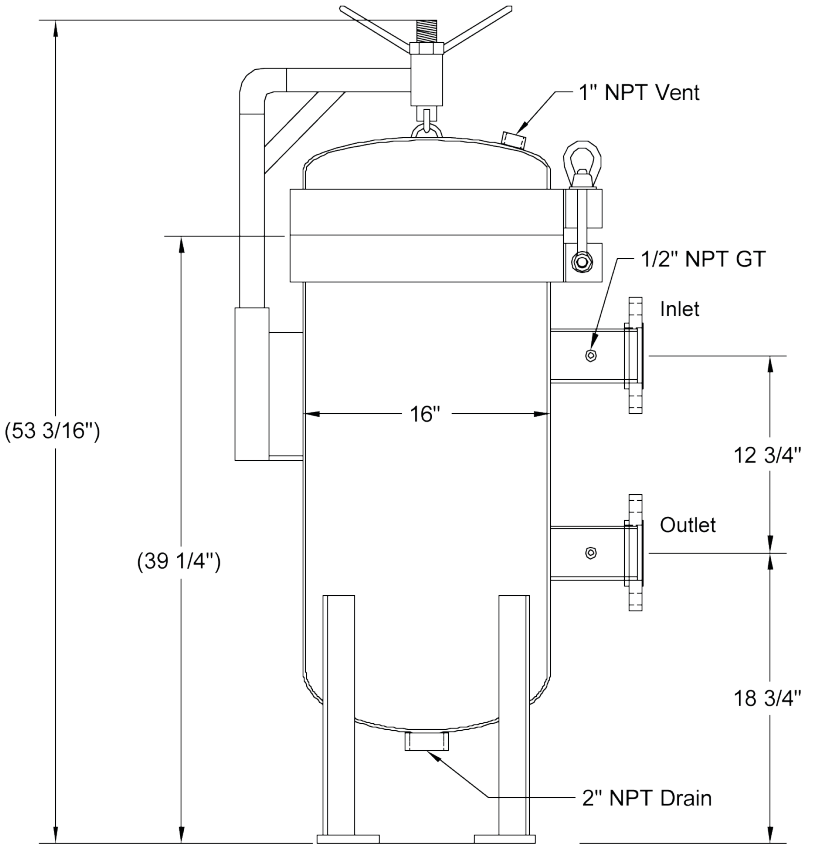

ORDER GUIDE

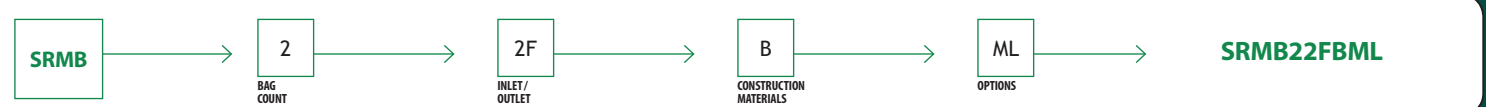

SRMB STANDARD FEATURES										
Inlet/Outlet Orientation: Ergonomically superior Side-in Side-out (standard) Bottom-in Bottom-out (optional)										
Low pressure drop	Positive cover seal									
Easily cleaned	Stainless Steel perforated baskets									
1" to 2" NPT drain port on bottom	0.5" to 1" NPT pressure gauge/vent tap									
Swing bolt closures	Davit Lift									
Pipe sizes from 2" to 14" RFF connections	Filter Bag Retainer Ring									
Differential pressure gauge taps										
SRMB OPTIONAL FEATURES										
Epoxy coating and fuse coating	Pressure ratings up to 300 psi									
Easily cleaned	Stainless Steel perforated baskets									
Mesh-lined basket for straining applications: 50 micron and higher	Wire mesh support baskets									
Choice of lid-lifting devices: Hydraulic-Jack or Manual Wheel Davit	ASME code stamp									
SRMB DIMENSIONS CHART , SIDE-IN / SIDE-OUT										
UNIT TYPE	BASKET COUNT	STANDARD CONNECTION	A Overall Height	B Height to opening	C Inlet to Outlet	D Diameter	SURFACE AREA (Sq. Ft.)	MAX GPM (Strainer)	MAX GPM (Filter Bags)	MAX SHIPPING WEIGHT (Lbs)
SRMB 2	2	3" RFF	55"	40"	123/4"	16"	9.0	600	400	380
SRMB 3	3	3" RFF	55"	40"	123/4"	18"	13.5	900	600	470
SRMB 4	4	4" RFF	55"	42"	123/4"	24"	18.0	1200	800	660
SRMB 5	5	6" RFF	60"	42"	123/4"	26"	22.5	1500	1000	775
SRMB 6	6	6" RFF	60"	42"	123/4"	26"	27.0	1800	1200	775
SRMB 8	8	8" RFF	66"	47"	16"	30"	35.5	2400	1600	900
SRMB 10	10	8" RFF	74"	52"	16"	36"	44.5	3000	2000	1250
SRMB 12	12	8" RFF	74"	52"	16"	36"	54.0	3600	2400	1350

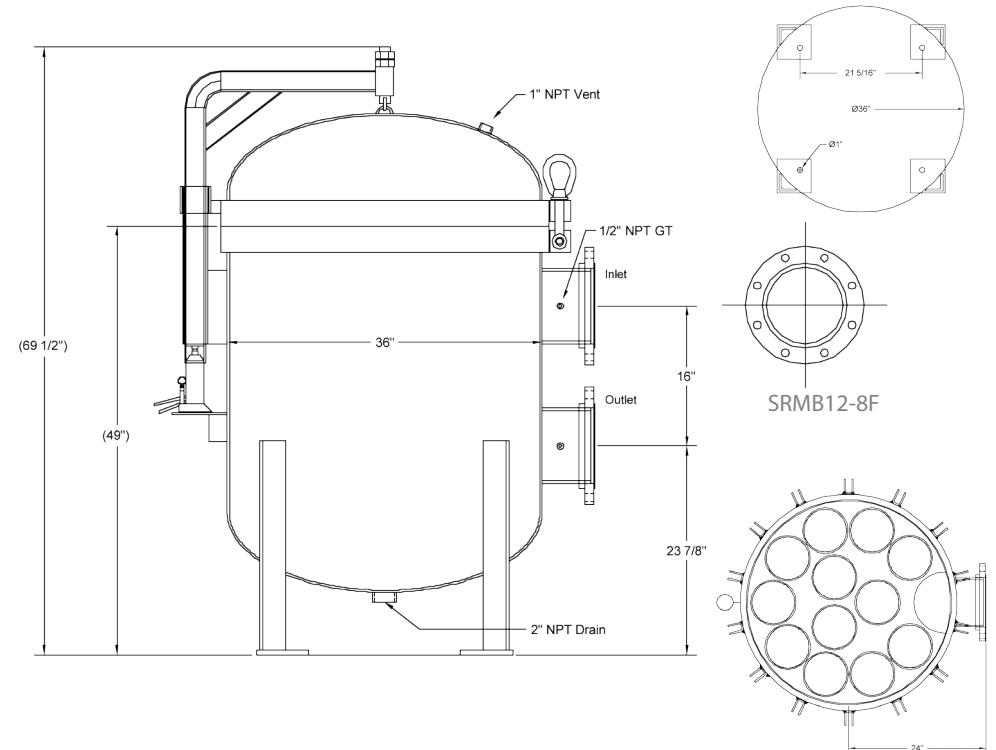

ORDER OPTIONS

VESSEL	
SRMB	Strainrite Multi-Bag Series
BAG COUNT	
2, 3, 4, 5, 6, 8, 10, 12	
INLET/OUTLET	
2 2F 3F 4F 6F 8F 10F	2" NPT 2" RFF 3" RFF 4" RFF 6" RFF 8" RFF 10" RFF
MATERIAL	
A B C	Carbon Steel 304 Stainless Steel 316 Stainless Steel
OPTIONS	
BIBO SIBO ML U SSB	Bottom in/Bottom out Side In/Bottom Out Mesh-Lined Basket 3rd Party ASME Code Inspected Swing Bolts/Eye Nut Stainless Steel

NEED ELEMENTS FOR YOUR VESSEL?
The following are most commonly used with the SRMB line:
MADD-MAXX—PAGES 74-95 FILTER BAGS—PAGES 98-123
As always, discuss your options with your local sales representative to find the best fit for your application.

This is not a comprehensive list. We can build your vessel to suit your specifications. Call one of our customer service representatives for pricing and availability.