

FILTER LIFE 0-15 PSID, MAXIMUM DIFFERENTIAL 25PSID
 #2 FLOW RANGE 1-150 GPM, MAXIMUM FLOW RATE 180 GPM
 #1 FLOW RANGE 1-75 GPM, MAXIMUM FLOW RATE 90 GPM
 SRHD-(BAG SIZE)-(I/O SIZE)-(MATERIAL)-(OPTION)

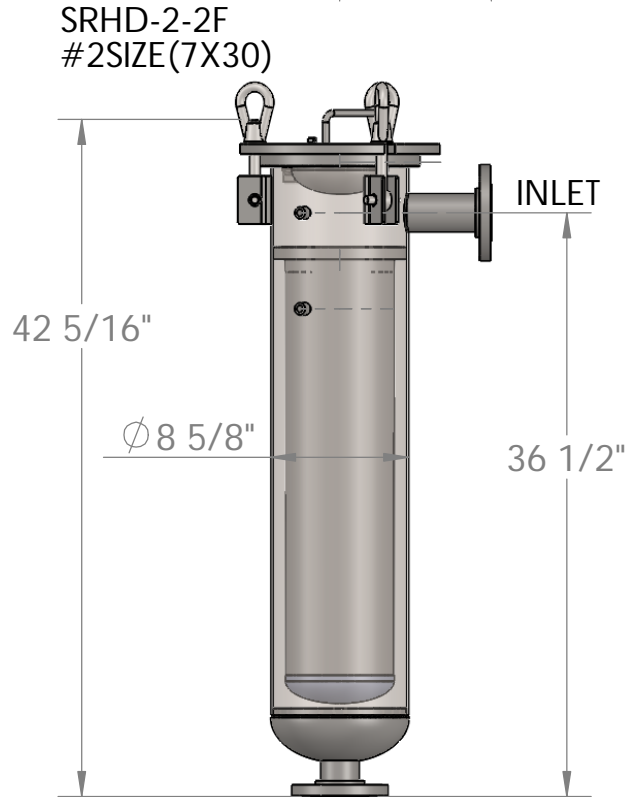
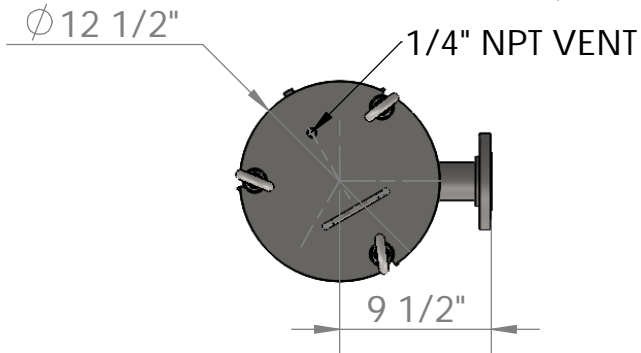

OUTLET

SHIPPING WEIGHT 95LBS #2, 85LBS #1
 15"X15"X48"
 SHOWN WITH OPTIONAL GAUGE PORTS

SRHD-1-2F
 #1 SIZE (7X15)

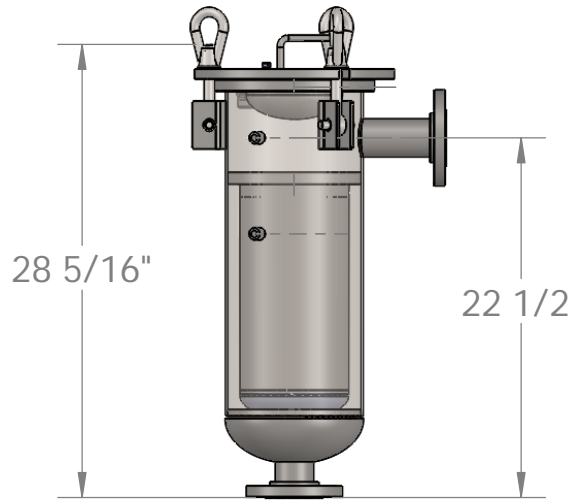

2" FLANGE
 150# B16.5

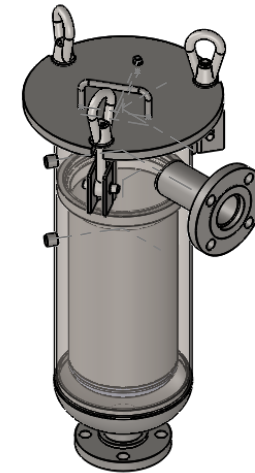

STANDARD EQUIPMENT:
 -#10 MESH SS BASKET
 -3-SWINGBOLT HINGED COVER
 -STEEL TRIPOD STAND
 -BUNA ORING COVER SEAL
 -BUNA ORING BASKET SEAL
 -MAWP 150 PSI @ 200F
 -UP TO 4" I/O CONNECTIONS

Prod Order: -	M.A.W.P. 150 P.S.I at 200 F
Customer: -	M.D.M.T. -20 F at 150 P.S.I
Cust. P.O.: -	Hydrostatic Test at 195 P.S.I
Cust. Tag: -	
Est. Weight 95 Lbs. Full XX Lbs.	MFG. Serial# TBD

THIS REPRODUCTION IS A PROPRIETARY DESIGN AND CONFIDENTIAL INFORMATION OF UF STRAINRITE INC. AND IS LOANED SUBJECT TO THE CONDITIONS THAT: (1) IT SHALL BE USED OR CAUSED TO BE USED FOR RECORD AND REFERENCE PURPOSES; (2) IT SHALL NOT BE USED OR CAUSED TO BE USED FOR PROCUREMENT IN ANY WAY PREJUDICIAL TO UF STRAINRITE INC. INTERESTS; (3) IT SHALL NOT BE REPRODUCED OR COPIED IN WHOLE OR IN PART; AND (4) IT SHALL NOT BE DISCLOSED AS GENERAL OR SPECIFIC INFORMATION WITHOUT EXPRESSED CONSENT IN WRITING SIGNED BY AN AUTHORIZED REPRESENTATIVE OF UF STRAINRITE INC

UNLESS OTHERWISE SPECIFIED
 DIMENSIONS ARE IN INCHES
 TOLERANCES:
 ANGLES ± 10° FRACTION: ± 1/8
 .XXX ± .XX .XX ± 0.0625

MATERIAL
 316-304-CS

Drawn By: DCB
 Date: 1/22/2019
 WPS: S1S R2
 Drawing: REF.

SRHD-REFERENCE

STRAINRITE INC
 65 First Flight Drive
 Auburn Maine
 (207) 777-3100