

FILTER LIFE 0-15 PSID, MAXIMUM DIFFERENTIAL 25PSID
 #2 FLOW RANGE 1-150 GPM, MAXIMUM FLOW RATE 180 GPM
 #1 FLOW RANGE 1-75 GPM, MAXIMUM FLOW RATE 90 GPM
 SRID-(BAG SIZE)-(I/O SIZE)-(MATERIAL)-(OPTION)

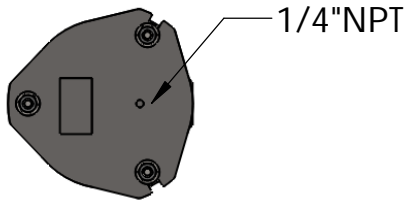

1/4"NPT

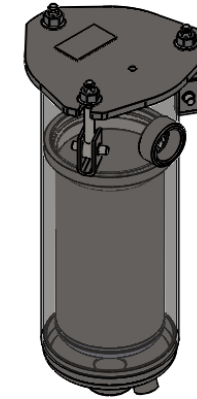

SRID-2-2
 #2SIZE(7X30)

SRID-1-2
 #1SIZE(7X15)

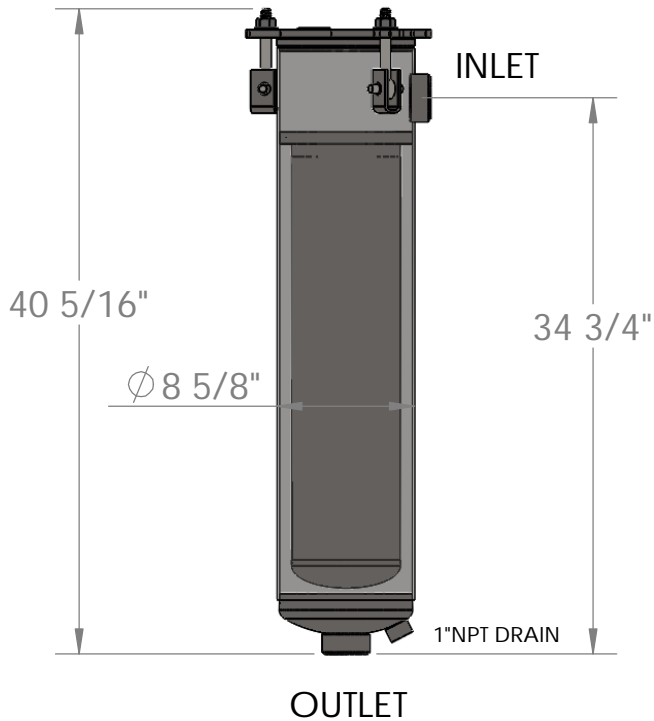

2" FLANGE
 150# B16.5

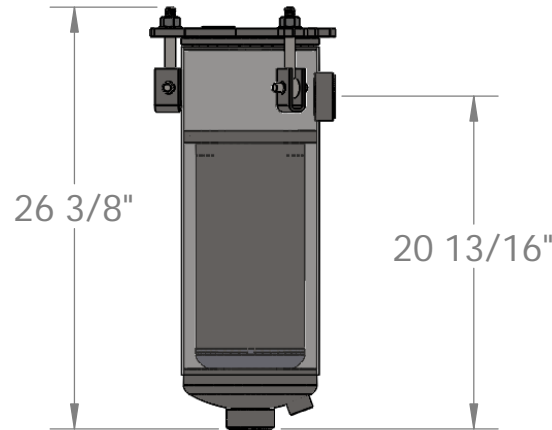

- STANDARD EQUIPMENT:
- 1/8" PERFORATED BASKET
 - 3-SWINGBOLT COVER
 - STEEL TRIPOD STAND
 - BUNA ORING COVER SEAL
 - BUNA ORING BASKET SEAL
 - MAWP 150 PSI @ 200F
 - UP TO 3" I/O CONNECTIONS

SHIPPING WEIGHT 95LBS #2, 85LBS #1
 15"X15"X48"

THIS REPRODUCTION IS A PROPRIETARY DESIGN AND CONFIDENTIAL INFORMATION OF UF STRAINRITE INC. AND IS LOANED SUBJECT TO THE CONDITIONS THAT: (1) IT SHALL BE USED OR CAUSED TO BE USED FOR RECORD AND REFERENCE PURPOSES; (2) IT SHALL NOT BE USED OR CAUSED TO BE USED FOR PROCUREMENT IN ANY WAY PREJUDICIAL TO UF STRAINRITE INC. INTERESTS; (3) IT SHALL NOT BE REPRODUCED OR COPIED IN WHOLE OR IN PART; AND (4) IT SHALL NOT BE DISCLOSED AS GENERAL OR SPECIFIC INFORMATION WITHOUT EXPRESSED CONSENT IN WRITING SIGNED BY AN AUTHORIZED REPRESENTATIVE OF UF STRAINRITE INC

UNLESS OTHERWISE SPECIFIED
 DIMENSIONS ARE IN INCHES
 TOLERANCES:
 ANGLES ± 10° FRACTION: ± 1/8
 .XXX=±XX .XX=±0.0625
 MATERIAL
 316-304-CS

Prod Order: -
 Customer: -
 Cust. P.O.: -
 Cust. Tag: -
 Est. Weight 95 Lbs. Full XX Lbs.

M.A.W.P. 150 P.S.I at 200 F
 M.D.M.T. -20 F at 150 P.S.I
 Hydrostatic Test at 195 P.S.I
 MFG. Serial# TBD

Drawn By: DCB
 Date: 1/22/2019
 WPS: SIS R2
 Drawing: REF.

SRID-REFERENCE
 STRAINRITE INC
 65 First Flight Drive
 Auburn Maine
 (207) 777-3100
 1:16 REV 0 | SHEET 1 OF 1 | ANSIA