

- STANDARD EQUIPMENT:  
 -PERFORATED SS BASKET  
 -3-SWINGBOLT COVER  
 -STEEL TRIPOD STAND  
 -BUNA ORING COVER SEAL  
 -BUNA ORING BASKET SEAL  
 -MAWP 150 PSI @ 200F

FILTER LIFE 0-15 PSID, MAXIMUM DIFFERENTIAL 25PSID  
 #2 FLOW RANGE 1-300 GPM, MAXIMUM FLOW RATE 360 GPM  
 #1 FLOW RANGE 1-150 GPM, MAXIMUM FLOW RATE 180 GPM  
 SRID-(BAG SIZE)-(I/O SIZE)-(MATERIAL)-(OPTION)

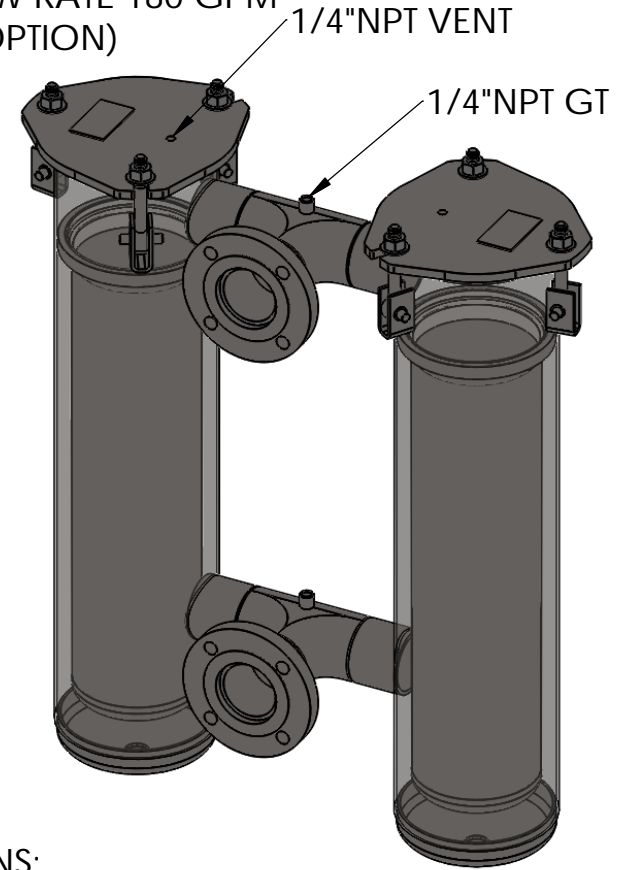
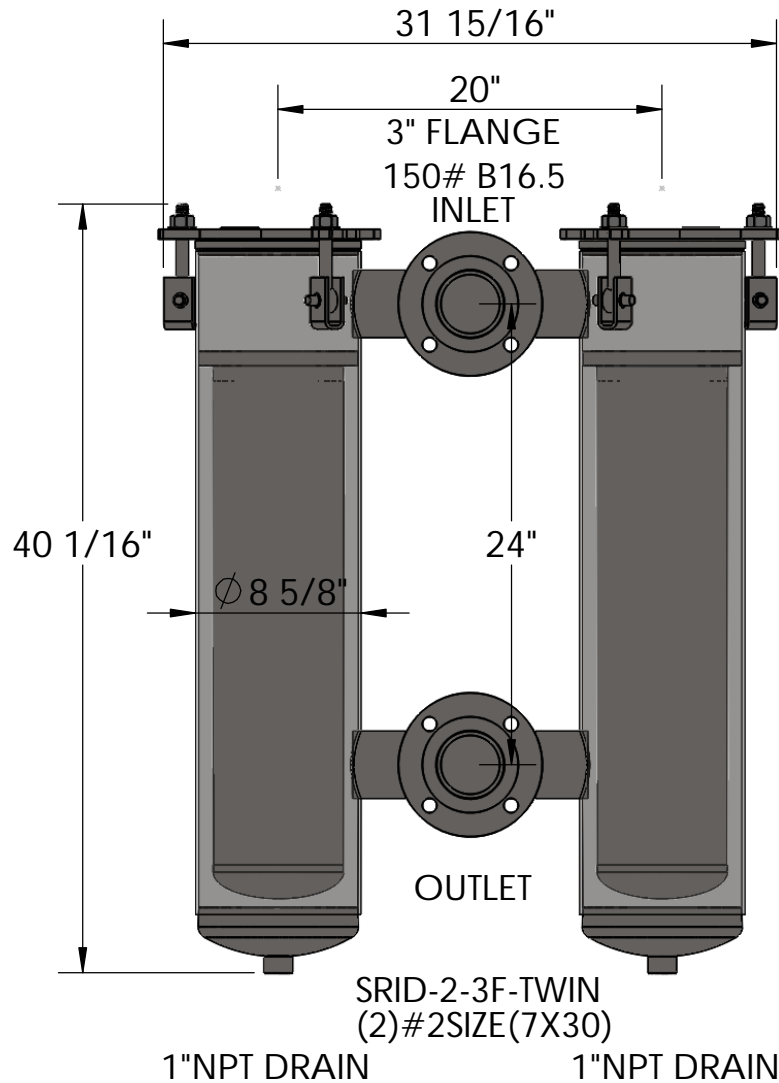

OPTIONS:  
 SO/SS=I/O SAME SIDE  
 SO/180=I/O OPPOSITE SIDE

SHIPPING WEIGHT 220LBS #2, 180LBS #1  
 48"X48"X48"

THIS REPRODUCTION IS A PROPRIETARY DESIGN AND CONFIDENTIAL INFORMATION OF UF STRAINRITE INC. AND IS LOANED SUBJECT TO THE CONDITIONS THAT: (1) IT SHALL BE USED OR CAUSED TO BE USED FOR RECORD AND REFERENCE PURPOSES; (2) IT SHALL NOT BE USED OR CAUSED TO BE USED FOR PROCUREMENT IN ANY WAY PREJUDICIAL TO UF STRAINRITE INC. INTERESTS; (3) IT SHALL NOT BE REPRODUCED OR COPIED IN WHOLE OR IN PART; AND (4) IT SHALL NOT BE DISCLOSED AS GENERAL OR SPECIFIC INFORMATION WITHOUT EXPRESSED CONSENT IN WRITING SIGNED BY AN AUTHORIZED REPRESENTATIVE OF UF STRAINRITE INC

UNLESS OTHERWISE SPECIFIED  
 DIMENSIONS ARE IN INCHES  
 TOLERANCES:  
 ANGLES ± 10° FRACTION: ± 1/8  
 .XXX=±XX .XX=±0.0625

MATERIAL  
 316-304-CS

Prod Order: -	M.A.W.P. 150 P.S.I at 200 F
Customer: -	M.D.M.T. -20 F at 150 P.S.I
Cust. P.O.: -	Hydrostatic Test at 195 P.S.I
Cust. Tag: -	
Est. Weight 220 Lbs. Full XX Lbs.	MFG. Serial# TBD

Drawn By: DCB  
 Date: 6/17/2019  
 WPS: S1S R2  
 Drawing: REF.

**SRID-TWIN**  
 STRAINRITE INC  
 65 First Flight Drive  
 Auburn Maine  
 (207) 777-3100  
 1:24 REV 0 | SHEET 1 OF 1 | ANSIA