

FILTER LIFE 0-15 PSID, MAXIMUM DIFFERENTIAL 25PSID
 #25 FLOW RANGE 1-25 GPM, MAXIMUM FLOW RATE 30 GPM
 #50 FLOW RANGE 1-50 GPM, MAXIMUM FLOW RATE 65 GPM
 SRL-(BAG SIZE)-(I/O SIZE)-(MATERIAL)-(OPTION)

SRL-50
 #50 SIZE(4X20)

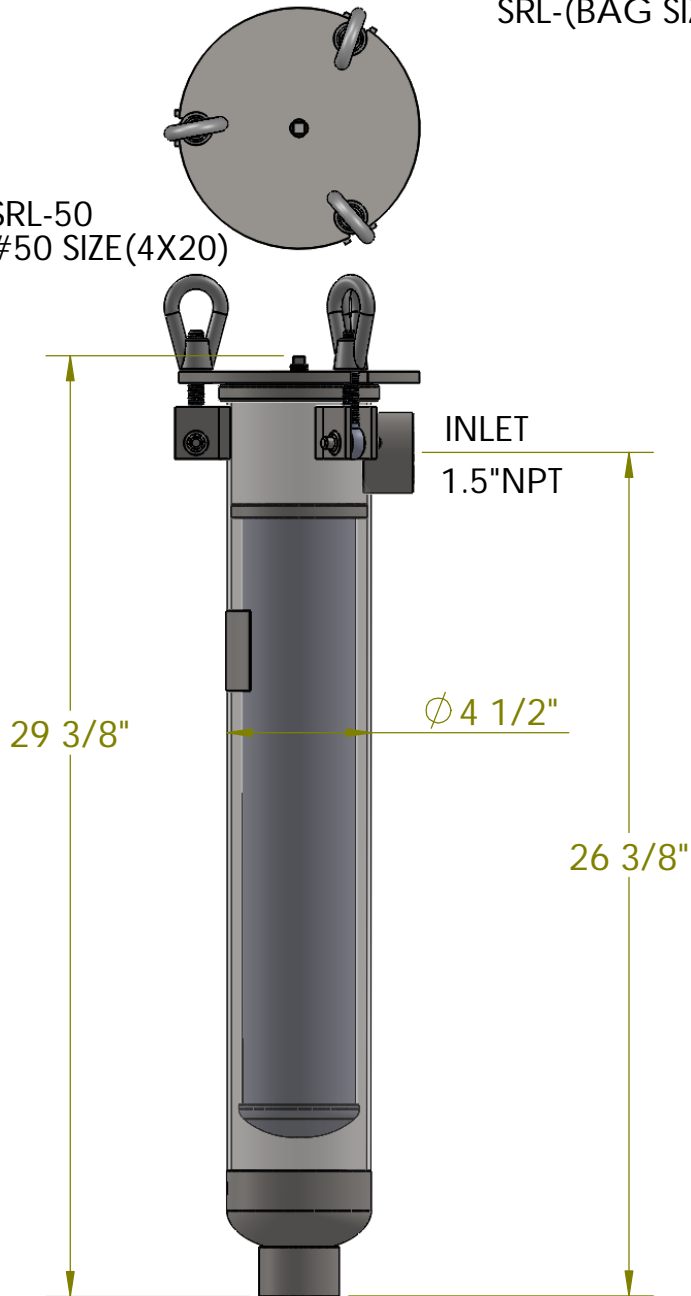

SHIPPING WEIGHT 16LBS #25, 24LBS #50
 6"X6"X36"

SRL-25
 #25 SIZE(4X10)

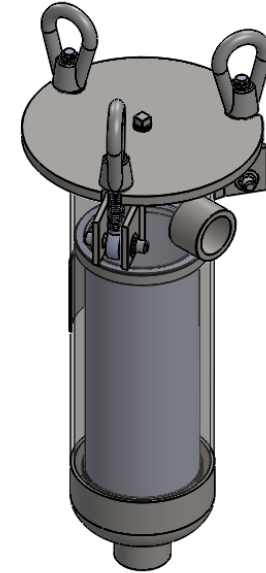
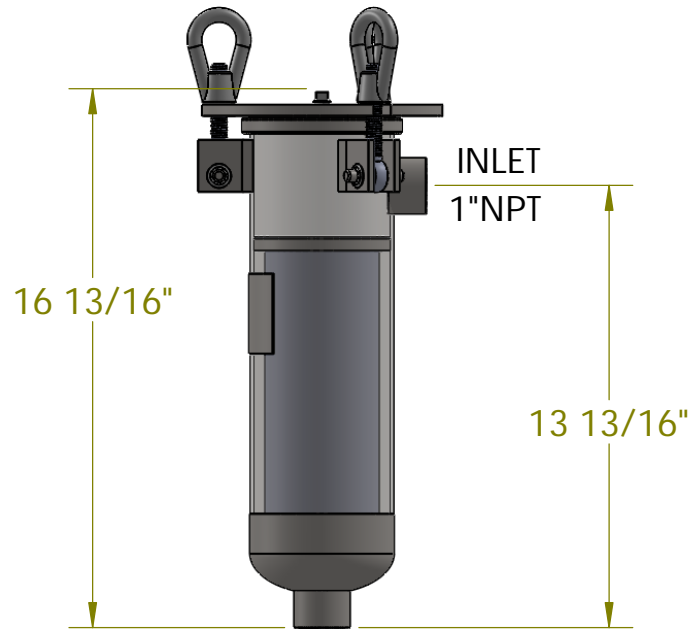

- STANDARD EQUIPMENT:
 -PERFORATED SS BASKET
 -SWING BOLT COVER
 -BUNA ORING COVER SEAL
 -MAWP 300 PSI @ 200F
 -UP TO 2" I/O CONNECTIONS

Prod Order: -	M.A.W.P. <u>300</u> P.S.I at <u>200</u> F
Customer: -	M.D.M.T. <u>-20</u> F at <u>300</u> P.S.I
Cust. P.O.: -	Hydrostatic Test at <u>130</u> P.S.I
Cust. Tag: -	
Est. Weight <u>XX</u> Lbs. Full <u>XX</u> Lbs.	MFG. Serial# <u>TBD</u>

THIS REPRODUCTION IS A PROPRIETARY DESIGN AND CONFIDENTIAL INFORMATION OF UF STRAINRITE INC. AND IS LOANED SUBJECT TO THE CONDITIONS THAT: (1) IT SHALL BE USED OR CAUSED TO BE USED FOR RECORD AND REFERENCE PURPOSES; (2) IT SHALL NOT BE USED OR CAUSED TO BE USED FOR PROCUREMENT IN ANY WAY PREJUDICIAL TO UF STRAINRITE INC. INTERESTS; (3) IT SHALL NOT BE REPRODUCED OR COPIED IN WHOLE OR IN PART; AND (4) IT SHALL NOT BE DISCLOSED AS GENERAL OR SPECIFIC INFORMATION WITHOUT EXPRESSED CONSENT IN WRITING SIGNED BY AN AUTHORIZED REPRESENTATIVE OF UF STRAINRITE INC

UNLESS OTHERWISE SPECIFIED
 DIMENSIONS ARE IN INCHES
 TOLERANCES:
 ANGLES ± 10° FRACTION: ± 1/8
 .XXX=±XX .XX=±0.0625
 MATERIAL
 316-304-CS

Drawn By: DCB
Date: 1/22/2019
WPS: SIS R2
Drawing: REF.

SRL-SB-REFERENCE
 STRAINRITE INC
 65 First Flight Drive
 Auburn Maine
 (207) 777-3100
 1:12 REV 0 | SHEET 1 OF 1 | ANSIA