

FILTER LIFE 0-15 PSID, MAXIMUM DIFFERENTIAL 25PSID
 10-BAG FLOW RANGE 1-1500 GPM, MAXIMUM FLOW RATE 1800 GPM WATER
 SRMB-(#BAGS)-(I/O SIZE)-(MATERIAL)-(OPTION)

SRMB-10-8F
 (10) #2SIZE(7X30)

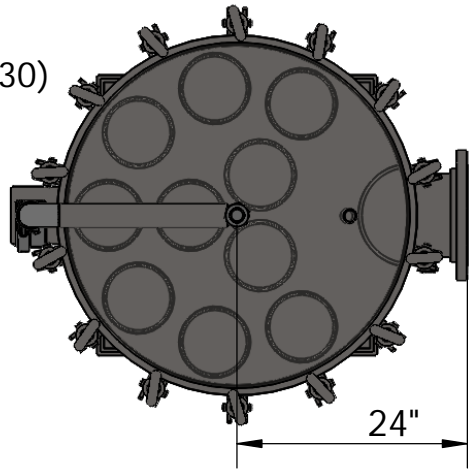

24"

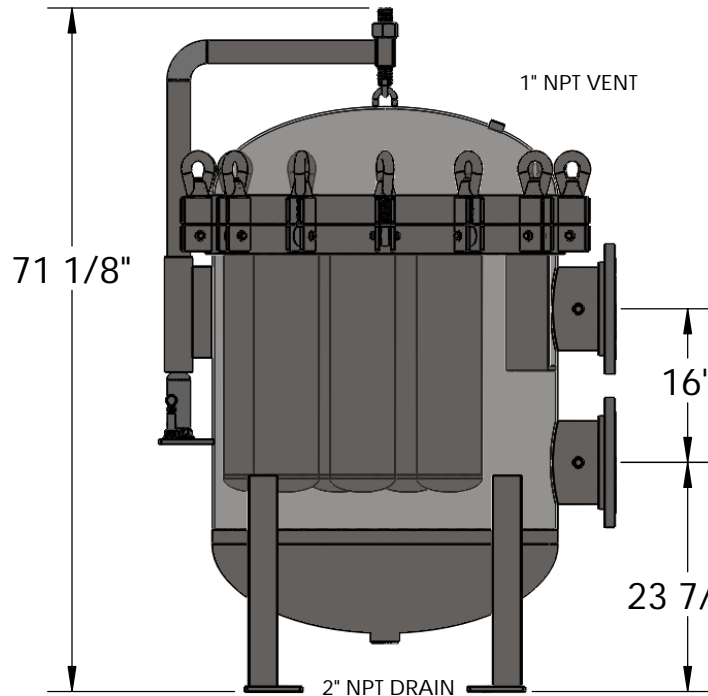
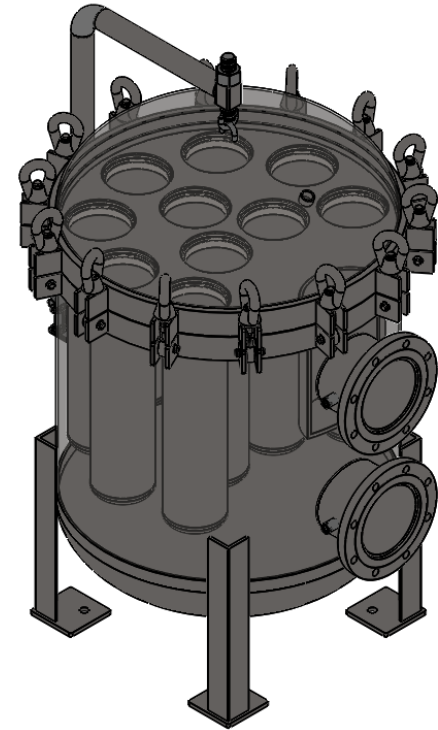

1" NPT VENT

8" FLANGE
 150# B16.5

INLET

16"

OUTLET

23 7/8"

2" NPT DRAIN

STANDARD EQUIPMENT:
 -PERFORATED STAINLESS BASKET
 -BUNA ORING SEAL
 -MAWP 150 PSI @ 200F

Prod Order: -	M.A.W.P. 150 P.S.I at 200 F
Customer: -	M.D.M.T. -20 F at 150 P.S.I
Cust. P.O.: -	Hydrostatic Test at 195 P.S.I
Cust. Tag: -	MFG. Serial# TBD
Est. Weight 1200 Lbs. Full 2200Lbs.	

SHIPPING WEIGHT 1200LBS
 74"X48"X48"

THIS REPRODUCTION IS A PROPRIETARY DESIGN AND CONFIDENTIAL INFORMATION OF UF STRAINRITE INC. AND IS LOANED SUBJECT TO THE CONDITIONS THAT: (1) IT SHALL BE USED OR CAUSED TO BE USED FOR RECORD AND REFERENCE PURPOSES; (2) IT SHALL NOT BE USED OR CAUSED TO BE USED FOR PROCUREMENT IN ANY WAY PREJUDICIAL TO UF STRAINRITE INC. INTERESTS; (3) IT SHALL NOT BE REPRODUCED OR COPIED IN WHOLE OR IN PART; AND (4) IT SHALL NOT BE DISCLOSED AS GENERAL OR SPECIFIC INFORMATION WITHOUT EXPRESSED CONSENT IN WRITING SIGNED BY AN AUTHORIZED REPRESENTATIVE OF UF STRAINRITE INC

UNLESS OTHERWISE SPECIFIED
 DIMENSIONS ARE IN INCHES
 TOLERANCES:
 ANGLES ± 10° FRACTION: ± 1/8
 .XXX±.XX .XX±0.0625

MATERIAL
 316-304-CS

Drawn By: DCB
Date: 7/31/2019
WPS: SIS R2
Drawing: REF.

SRMB-10-REFERENCE

STRAINRITE INC
 65 First Flight Drive
 Auburn Maine
 (207) 777-3100