

FILTER LIFE 0-15 PSID, MAXIMUM DIFFERENTIAL 25PSID  
 12-BAG FLOW RANGE 1-1800 GPM, MAXIMUM FLOW RATE 2100 GPM WATER  
 SRMB-(#BAGS)-(I/O SIZE)-(MATERIAL)-(OPTION)

SRMB-12-8F  
 (12) #2SIZE(7X30)

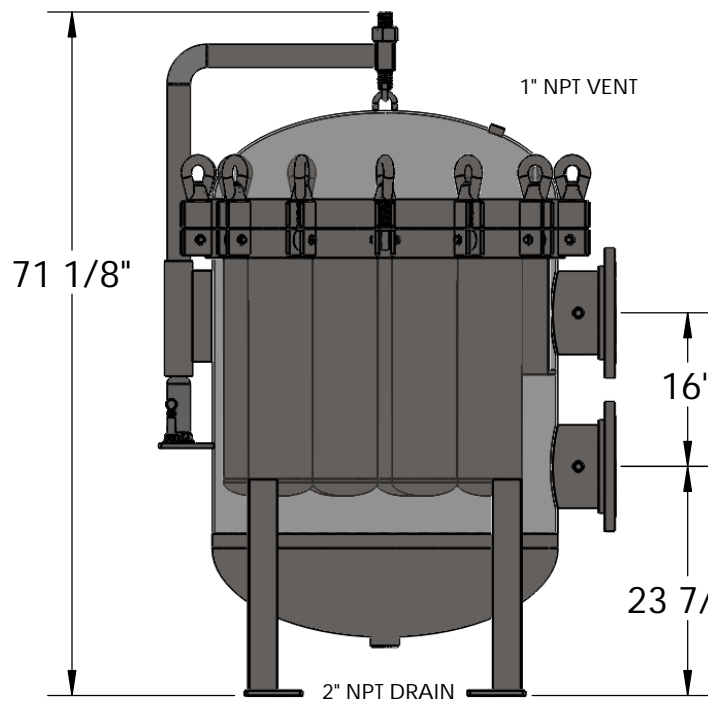
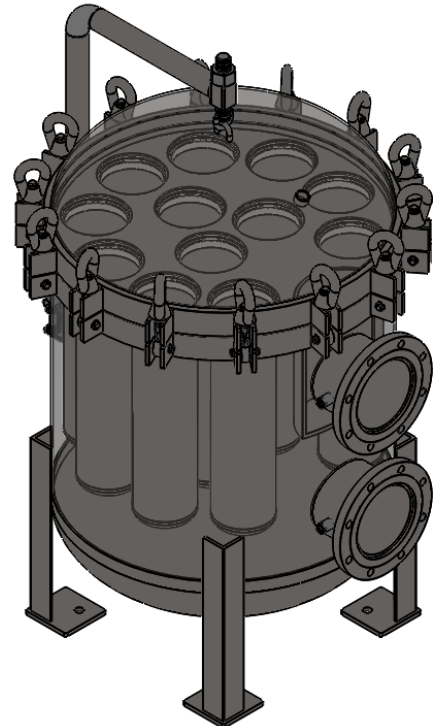
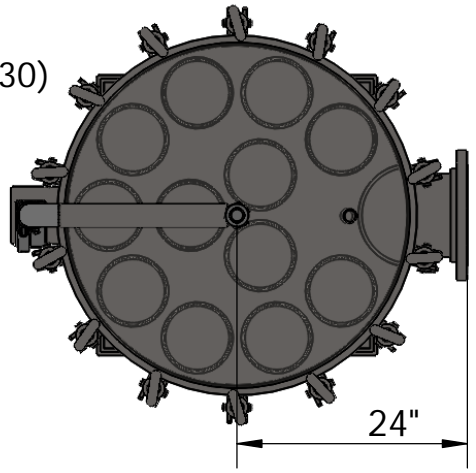

8" FLANGE  
 150# B16.5

INLET

OUTLET

STANDARD EQUIPMENT:  
 -PERFORATED STAINLESS BASKET  
 -BUNA ORING SEAL  
 -MAWP 150 PSI @ 200F

Prod Order: -	M.A.W.P. <u>150</u> P.S.I at <u>200</u> F
Customer: -	M.D.M.T. <u>-20</u> F at <u>150</u> P.S.I
Cust. P.O.: -	Hydrostatic Test at <u>195</u> P.S.I
Cust. Tag: -	MFG. Serial# <u>TBD</u>
Est. Weight <u>1200</u> Lbs. Full <u>2200</u> Lbs.	

SHIPPING WEIGHT 1200LBS  
 74"X48"X48"

THIS REPRODUCTION IS A PROPRIETARY DESIGN AND CONFIDENTIAL INFORMATION OF UF STRAINRITE INC. AND IS LOANED SUBJECT TO THE CONDITIONS THAT: (1) IT SHALL BE USED OR CAUSED TO BE USED FOR RECORD AND REFERENCE PURPOSES; (2) IT SHALL NOT BE USED OR CAUSED TO BE USED FOR PROCUREMENT IN ANY WAY PREJUDICIAL TO UF STRAINRITE INC. INTERESTS; (3) IT SHALL NOT BE REPRODUCED OR COPIED IN WHOLE OR IN PART; AND (4) IT SHALL NOT BE DISCLOSED AS GENERAL OR SPECIFIC INFORMATION WITHOUT EXPRESSED CONSENT IN WRITING SIGNED BY AN AUTHORIZED REPRESENTATIVE OF UF STRAINRITE INC

UNLESS OTHERWISE SPECIFIED  
 DIMENSIONS ARE IN INCHES  
 TOLERANCES:  
 ANGLES ± 10° FRACTION: ± 1/8  
 .XXX=±XX .XX=±0.0625

MATERIAL  
 316-304-CS

Drawn By: DCB
Date: 7/31/2019
WPS: SIS R2
Drawing: REF.

SRMB-12-REFERENCE

STRAINRITE INC  
 65 First Flight Drive  
 Auburn Maine  
 (207) 777-3100

1:32 REV 0 | SHEET 1 OF 1 | ANSI A