

CARTRIDGE VESSEL
 FILTER CARTRIDGE LIFE 0-20 PSID
 MAXIMUM DIFFERENTIAL PRESSURE 25 PSID

FLOW RANGE 30" CTK 1-65 GPM , MAXIMUM FLOW RATE 75 GPM WATER

HOLDS (5) DOE OR 222(C1,C3,C8)
 DESIGN PRESSURE 150PSI @ 300F
 NON-CODE MILD SERVICE
 (PSV) PRESSURE SAFETY VALVE NOT SUPPLIED

REVISIONS			
LTR	DESCRIPTION	DATE	APPROVAL
0	new	xx	xx

SRVC-B5-302FV
 106517

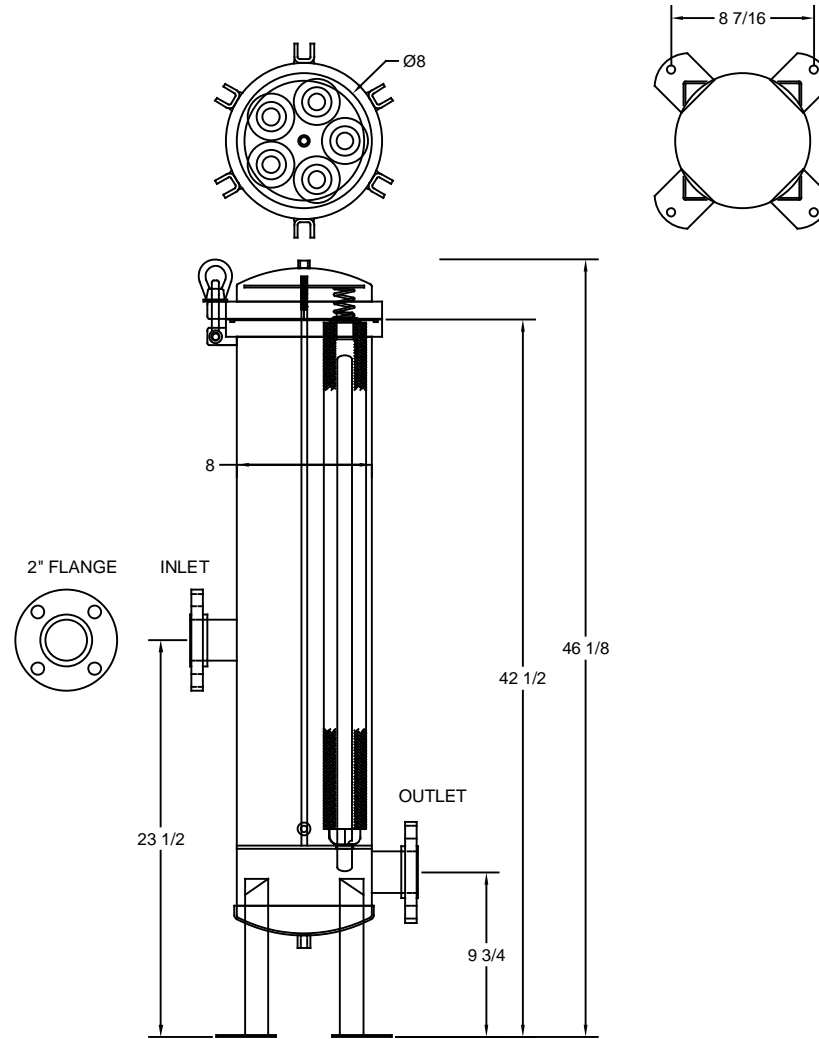

EST. SHIPPING WEIGHTS

30" 60 LBS

THIS REPRODUCTION IS A PROPRIETARY DESIGN AND CONFIDENTIAL INFORMATION OF UF STRAINRITE INC. AND IS LOANED SUBJECT TO THE CONDITIONS THAT: (1) IT SHALL BE USED OR CAUSED TO BE USED FOR RECORD AND REFERENCE PURPOSES; (2) IT SHALL NOT BE USED OR CAUSED TO BE USED FOR PROCUREMENT IN ANY WAY PREJUDICIAL TO UF STRAINRITE INC. INTERESTS; (3) IT SHALL NOT BE REPRODUCED OR COPIED IN WHOLE OR IN PART; AND (4) IT SHALL NOT BE DISCLOSED AS GENERAL OR SPECIFIC INFORMATION WITHOUT EXPRESSED CONSENT IN WRITING SIGNED BY AN AUTHORIZED REPRESENTATIVE OF UF STRAINRITE INC.

UNLESS OTHERWISE SPECIFIED DIMENSIONS ARE IN INCHES. TOLERANCES ARE AS FOLLOWS:
 FRACTION ± 1/8 ANGLES ± 10°
 XX = ± .020 XXX = ± .005
 MATERIAL: **STAINLESS**

SRVC-B5-302FV	
DRAWN BY: DCB	STRAINRITE INC
DATE: 3-18-16	65 First Flight Drive
APPROVAL:	Auburn Maine
ENG #: -	(207) 777-3100
SCALE: xx	SHT. 1 OF 1 C